

ADTRAN
DSU 56/64
Data Service Unit
USER MANUAL

61200.062L1-1D
May 1997



901 Explorer Boulevard
P.O. Box 140000
Huntsville, AL 35814-4000
Phone: (205) 963-8000

© 1997 ADTRAN, Inc.
All rights reserved.
Printed in USA.

FCC regulations require that the following information be provided in this manual:

1. This equipment complies with Part 68 of the FCC rules. On the bottom of the equipment housing is a label that shows the FCC registration number and Ringer Equivalence Number (REN) for this equipment. If requested, provide this information to the telephone company.
2. If this equipment causes harm to the telephone network, the telephone company may temporarily discontinue service. If possible, advance notification is given, otherwise, notification is given as soon as possible. The telephone company will advise the customer of the right to file a complaint with the FCC.
3. The telephone company may make changes in its facilities, equipment, operations, or procedures that could affect the proper operation of this equipment; advance notification and the opportunity to maintain uninterrupted service is given.
4. If experiencing difficulty with this equipment, please contact ADTRAN for repair and warranty information. The telephone company may require this equipment to be disconnected from the network until the problem is corrected, or it is certain the equipment is not malfunctioning.
5. This unit contains no user serviceable parts.
6. An FCC compliant telephone cord with a modular plug is provided with this equipment. This equipment is designed to be connected to the telephone network or premises wiring using an FCC compatible modular jack, which is Part 68 compliant.
7. The following information may be required when applying to the local telephone company for leased line facilities.

Service Type	Digital Facility Interface Code	Service Order Code	Network Jacks
56 kbps Digital Interface	04DU5-56	6.0F	RJ-48S

**FEDERAL COMMUNICATIONS COMMISSION
RADIO FREQUENCY INTERFERENCE STATEMENT**

This equipment has been tested and found to comply with the limits for a Class A digital device, Pursuant to Part 15 of the FCC Rules. These limits are designed to provide reasonable protection against harmful interference when the equipment is operated in a commercial environment. This equipment generates, uses, and can radiate radio frequency energy and, if not installed and used in accordance with the instruction manual, may cause harmful interference to radio frequencies. Operation of this equipment in a residential area is likely to cause harmful interference in which case the user will be required to correct the interference at his own expense.

Shielded cables must be used with this unit to ensure compliance with Class A FCC limits.



Change or modifications to this unit not expressly approved by the party responsible for compliance could void the user's authority to operate the equipment.

CANADIAN EMISSIONS REQUIREMENTS

This digital apparatus does not exceed the Class A limits for radio noise emissions from digital apparatus as set out in the interference-causing equipment standard entitled "Digital Apparatus," ICES-003 of the Department of Communications.

Cet appareil numérique respecte les limites de bruits radioélectriques applicables aux appareils numériques de Class A prescrites dans la norme sur le matériel brouilleur: "Appareils Numériques," NMB-003 édictée par le ministre des Communications.

Table of Contents

Chapter 1. Introduction

General Description	1
Physical Description	2
Front Panel	3
LED Identification	3
DTE Status (Green)	3
Network Status (Red)	3
Test Status/ Error (Yellow/ Red)	3
Test Switches	4
Rear Panel	5

Chapter 2. Installation

Unpack, Inspect, Power Up	7
Receiving Inspection	7
ADTRAN Shipments Include	7
Customer Provides	7
Power Up	8
Warranty and Customer Service	9
Configuration	10
Clear To Send (CS) - SW 1	10
Clear To Send Delay (CS Delay) - SW 2	10
Antistream - SW 3	10
Carrier Detect (CD) - SW 4	11
Data Set Ready (SR) - SW 5	11
Remote Digital Loopback (RDL) - SW 6	11
Loop Rate - SW 7	12
Scrambler - SW 8	12
Network Connections	13
DTE Connector	13

Chapter 3. Test Modes

Self Test	15
Near End Tests	16
DTE Only Test	16
DTE with Test Pattern (TP)	18
DTE and Loop Test (LL)	20

Loop Only Test	22
Far End Tests	23
Remote Digital Loopback (RDL)	23
RDL with Test Pattern (TP)	23
Test Pattern (PTRN)	24
Remote Tests	25

Chapter 4. Specifications Summary

Specifications and Features	27
Loop Interface	27
Line Requirements	27
Loop Rates	27
Receiver Sensitivity	27
DTE Interfaces	27
DTE Operating Modes	27
DTE Data Rates	27
Diagnostics	28
Power	28
Environment	28

Index	29
--------------------	-----------

List of Tables

Table 2-A Network Connections	13
Table 2-B DTE Pin Assignments	14

List of Figures

Figure 1-1 DSU 56/64 Front Panel	1
Figure 1-2 DSU 56/64 Rear Panel	5
Figure 3-1 DTE Only Test Diagram	17
Figure 3-2 DTE with TP Test Diagram	19
Figure 3-3 DTE and Loop Test Diagram	21
Figure 3-4 Loop Only Test Diagram	22

Chapter 1

Introduction

GENERAL DESCRIPTION

The ADTRAN DSU 56/64, Figure 1-1, is a technologically advanced, high performance Data Service/Channel Service Unit (DSU/CSU) that provides the interface between telco provided Digital Data Service (DDS) and the customer's Data Terminal Equipment (DTE).

The DSU 56/64 supports both 56 kbps and 64 kbps loop service rates with the DTE interface rate matching the selected loop rate. A synchronous V.35 interface is provided for the DTE interface.

All setup or configuration is accomplished with a single eight-position DIP switch that is accessible from the back panel of the unit.

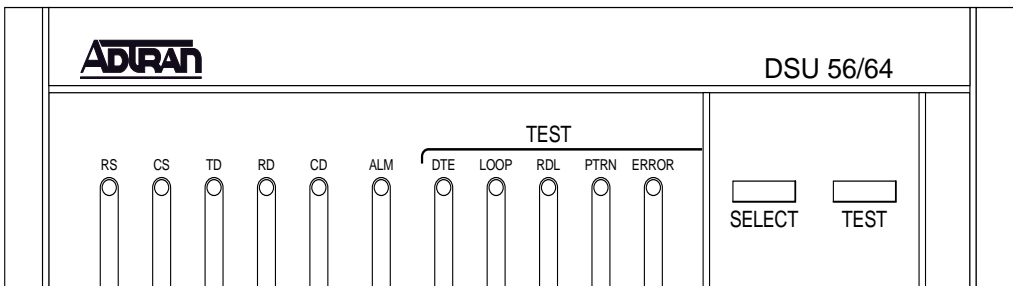

Figure 1-1
DSU 56/64 Unit

PHYSICAL DESCRIPTION

The DSU 56/64 is a single stand-alone unit designed to be used either on a desktop or mounted on a wall. The physical measurements of the DSU 56/64 are as follows:

Length = 8.32 inches
Width = 6.50 inches
Height = 1.56 inches
Weight = 1.50 pounds

Front Panel

As shown in Figure 1-1, the front panel of the DSU 56/64 contains eleven light emitting diode (LED) indicators that display DTE interface, network, and test status. These indicators are defined in the section *LED Identification*.

LED Identification

DTE Status (Green)

INDICATOR	DEFINITION	SOURCE
RS	Request To Send	DTE
CS	Clear To Send	DSU
TD	Transmit Data	DTE
RD	Receive Data	DSU
CD	Carrier Detect	DSU



NOTE

The active state for the status indicators (RS, CS, and CD) is **On** while the on state for the data indicators (TD and RD) represents a **Space** condition.

Network Status (Red)

ALM *On* indicates a problem on the local loop or within the DDS network.

Off indicates normal loop and network conditions.

Test Status/Error (Yellow/Red)

DTE *On* solid indicates DTE interface test in progress.
Flashing indicates Loop Interface test (CSU Loopback) has been initiated by telco.

Loop *On* solid indicates loop interface test has been initiated from local DSU.
Flashing indicates loop interface test (CSU or DSU Loopback) has been initiated by telco.

RDL	<i>On</i> solid indicates remote digital loopback test has been initiated from the local DSU. <i>Flashing</i> indicates remote digital loopback test has been initiated from the remote DSU.
PTRN	<i>On</i> solid indicates that integral pattern generator is being utilized for testing.
Error	<i>On</i> indicates that errors are being detected during a test or that a test can not be properly initiated.

Tests defined by the above indicators are explained in greater detail in the chapter *Test Modes*.

Test Switches

The front panel also contains two push-button switches for selecting and controlling the various test modes for the DSU 56/64. The descriptions of these switches are as follows:

Select	Each time this switch is activated a valid test mode is indicated by one or more LEDs being turned on solid.
Test	Once the desired test mode is displayed on the test status indicators, the test is initiated by activating this switch. This switch is also activated to terminate any test in progress.

Rear Panel

The rear panel of the DSU 56/64 is shown in Figure 1-2. The thirty-four pin connector labeled **PRIMARY V.35** provides the synchronous DTE interface. The eight-pin modular jack (RJ-48S) labeled **TELCO** connects the DSU 56/64 to the DDS network. The pin assignments for these connectors are described in the sections *Network Connections* and *DTE Connections*.

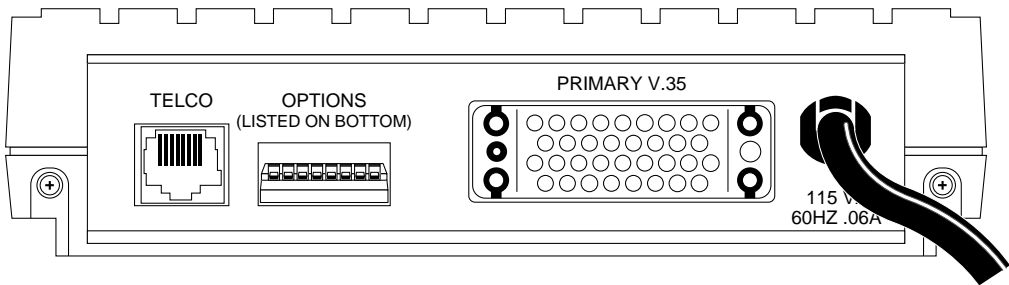

Figure 1-2
DSU 56/64 Rear Panel

All setup or configuration parameters for the DSU 56/64 are selected with an eight-position DIP switch. This switch, labeled **OPTIONS**, is accessible from the rear panel. The label also references the options chart located on the bottom of the unit. The individual options are explained in detail in the section *Configuration*.

The power cord on the rear panel of the DSU 56/64 is mechanically secured to the back panel and provides the connections to the integral AC/DC power supply.

Chapter 2

Installation

UNPACK, INSPECT, POWER UP

Receiving Inspection

Carefully inspect the DSU 56/64 for any shipping damages. If damage is suspected, file a claim immediately with the carrier and then contact ADTRAN Customer Service. If possible, keep the original shipping container for use in returning the unit for repair or for verification of damage during shipment.

ADTRAN Shipments Include

The following items are included in ADTRAN shipments of the DSU III TDM:

- The DSU 56/64 unit
- Network interface cable
An 8-position modular to 8-position modular
- The DSU 56/64 User Manual

Customer Provides

The customer must provide a V.35 cable.

Power Up

The DSU 56/64 is equipped with a captive six-foot power cord that is terminated with a three-prong plug for connecting to a grounded power receptacle.



NOTE

Ensure that a grounded, 115 VAC, 60 Hz receptacle is used for powering the DSU 56/64.

When plugged into a source of AC power, the DSU 56/64 performs a self test to verify all LED indicators plus various circuit blocks within the unit. See the section *Self Test*.

WARRANTY AND CUSTOMER SERVICE

ADTRAN will replace or repair this product within five years from the date of shipment if it does not meet its published specifications or fails while in service. For detailed warranty, repair and return information refer to the ADTRAN Equipment Warranty and Repair and Return Policy Procedure.

Return Material Authorization (RMA) is required prior to returning equipment to ADTRAN.

For service, RMA requests or more information, contact one of the numbers listed on the inside back cover of this manual.

Configuration

The DSU 56/64 has eight options for controlling the operation of both the network and DTE interfaces. These options are selected by setting individual switches on the eight-position DIP switch that is accessible from the rear panel. A chart showing the options and switch settings is attached to the bottom of the unit.

Clear To Send (CS) - SW 1

Down - Normal

In the **Down** position CS follows the RS lead with the selected amount of delay. The only exceptions to this occur when network or test conditions prevent data from being transferred over the DTE interface. During these conditions CS is turned off.

Up - On

CS is forced on all the time.

Clear To Send Delay (CS Delay) - SW 2

Switch Position	RS To CS Delay
Down - Short	250 μ s \pm 125 μ s
Up - Long	10 ms \pm 125 μ s

Antistream - SW 3

The **Antistream** option is used to select the antistream time out. The antistream time out is the maximum time the DSU 56/64 is allowed to transmit data from the DTE into the network. This feature prevents one DTE device on a multi-drop network from continuously tying up the transmit circuit from a remote DSU back to the master DSU.

The antistream timer is reset to zero when RS transitions to the active state and is updated every second while RS is active. When the antistream time out expires, the DSU 56/64 stops transmitting DTE data into the network. It does, however, continue to accept data. CS is maintained in the active state until the DTE deactivates the RS input.

Down - Off

The Antistream timer is disabled.

Up - On

The Antistream timer is enabled and set for 45 +/- 0.5 seconds.

Carrier Detect (CD) - SW 4

Down - Normal

CD is on any time customer data is being received and off when the receive circuit is idle, not carrying customer data.

Up - On

CD is forced on all the time.

Data Set Ready (SR) - SW 5

Down - On

SR is forced on all the time.

Up - Normal

SR is only turned off when the network is out of service or a test is in progress.

Remote Digital Loopback (RDL) - SW 6

Down - Enable

The DSU 56/64 accepts the industry standard V.54 RDL command from the far end of the circuit.

Up - Disable

The DSU 56/64 does not respond to the V.54 loopback command from the far end of the circuit.

Loop Rate - SW 7

Down - 56 kbps

The network interface of the DSU 56/64 is configured for operation at 56 kbps.

Up - 64 kbps

The network interface is configured for 64 kbps operation.

Scrambler - SW 8

For 64 kbps clear channel operation, there is a possibility that the DTE data sequences might mimic network loop maintenance functions and erroneously cause other network elements to activate loopbacks. To prevent this, the **Scrambler** switch should be set to the **Down** (ON) position.

The **Scrambler On** option must be selected in both the local and remote 56/64 DSUs for the situation described above.

This option is only valid when the 64 kbps rate is selected.

Down - On

The scrambler is enabled.

Up - Off

The scrambler is disabled.

NETWORK CONNECTIONS

This interface consists of four leads that are paired to provide separate transmit and receive circuits. The four leads are provided on the eight-position modular jack DSU RJ-48S labeled **TELCO** on the rear panel of the DSU 56/64. The pin assignments for this connector are shown in Table 2-A.

Table 2-A
Network Connections

Pin Number	Function	Signal Direction
1	Transmit Data (R)	From Customer to Network Interface
2	Transmit Data (T)	From Customer to Network Interface
3-6	Not Used	
7	Receive Data (T-1)	From Network Interface to Customer
8	Receive Data (R-1)	From Network Interface to Customer

DTE Connector

The Data Terminal Equipment is attached to the connector labeled **PRIMARY V.35** at the rear of the DSU 56/64. Table 2-B shows the pin assignments for all pins used on this connector.

Table 2-B
DTE Pin Assignments

Pin	CCITT	Description
A	101	Protective Ground (PG)
B	102	Signal Ground (SG)
C	105	Request to Send (RS)
D	106	Clear to Send (CS)
E	107	Data Set Ready (SR)
F	109	Receive Line Signal Detector (CD)
R	104	Received Data (RD-A)
T	104	Received Data (RD-B)
V	115	Receiver Signal Element Timing (SCR-A)
X	115	Receiver Signal Element Timing (SCR-B)
P	103	Transmitted Data (SD-A)
S	103	Transmitted Data (SD-B)
Y	114	Transmitter Signal Element Timing (SCT-A)
AA	114	Transmitter Signal Element Timing (SCT-B)
U	113	External TX Signal Element Timing (SCX-A)
W	113	External TX Signal Element Timing (SCX-B)



A shielded V.35 cable is required to prevent possible radio frequency interference emissions.

Chapter 3

Test Modes

In addition to a self test mode, the DSU 56/64 has other extensive test modes which are designed to help isolate problems to specific components of the communications circuit. These various test modes for the DSU 56/64 are initiated and terminated from the front panel using the **Select** and **Test**.

SELF TEST

When the DSU 56/64 is powered on, all LEDs on the front panel turn *On* simultaneously for approximately two seconds. After the two seconds, all the LEDs turn *Off* briefly. The LEDs then cycle *On* in pairs with a fan-out pattern away from the ALM indicator. Next, the LEDs cycle *Off* in pairs with a fan-in pattern back towards the ALM indicator. These patterns are repeated four times for visual verification that all LEDs are functioning properly.

At the completion of the LED test patterns the PTRN LED is *On* indicating that the DTE with TP test is being performed. This test is successful when the **Error** indicator does not turn *On*. If the DTE with TP test fails, the **RS**, **ALM**, **DTE**, **PTRN**, and **Error** indicators all *Flash*.

If a EPROM CHECKSUM failure is detected during self test, **CS**, **ALM**, **PTRN**, and **Error** indicators all *Flash* at the end of the self test.

NEAR END TESTS

The local DSU 56/64 is capable of performing the following near end tests:

- DTE Only
- DTE with Test Pattern
- DTE and LOOP (LL)
- Loop Only (RT)

DTE Only Test

The DTE Only test provides a method for testing both the DTE interface of the local DSU 56/64 plus its loop transmitter and receiver. For this test, the loop transmit data is connected to the loop receive data at a point close to the physical network interface. A block diagram illustrating the loopback point and the signal paths for this test is shown in Figure 3-1.

To initiate the DTE Only test, perform the following steps:

1. Press **Select** once to turn *On* the DTE test indicator.
2. Press **Test** while the test indicator is *On*.

To terminate this test, press **Test**.

Test data from the terminal or test equipment is routed through the DTE section of the DSU 56/64 and then to the output of the loop transmitter section where the signal is encoded for transmission. The output of the loop transmitter is coupled back to the loop receiver input. The received test signal is then decoded and returned to the terminal or test equipment where it is checked for any bit errors.

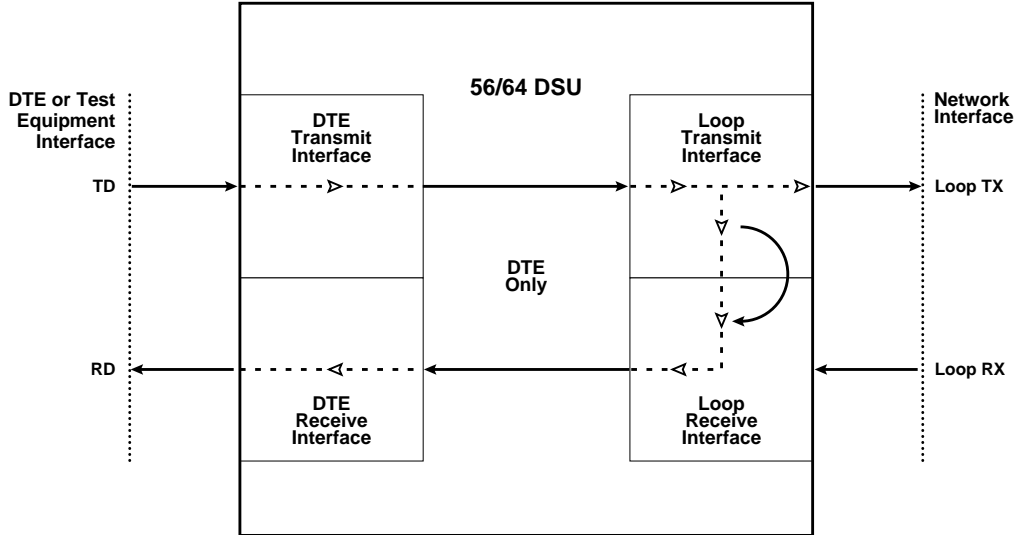

Figure 3-1
DTE Only Test Diagram

DTE with Test Pattern (TP)

The DTE with TP test is similar to the DTE Only test previously described. It is initiated at the local DSU 56/64 and is used to independently test the operation of the DSU 56/64.

To initiate the DTE with TP test, perform the following steps:

1. Press **Select** twice to turn *On* both the **DTE** and **PTRN** test indicators.
2. Press **Test** while these test indicators are *On*.

To terminate this test, press **Test**.

Instead of using data from the terminal or test equipment, this test utilizes an internal test pattern generator and detector in the DSU 56/64. The loopback point and the data paths for this test are illustrated in Figure 3-2.

The internal test pattern generator and detector of the DSU 56/64 operate with a 2047 data pattern. When this test is initiated, the test pattern detector examines the receive data stream until synchronization to the 2047 pattern is achieved. Once synchronized, the detector continues to check the receive data and reports any detected bit errors by turning *On* the **Error** LED.

Once a test is initialized with the internal test pattern generator and detector, errors can be injected into the transmit data stream by pressing **Select** and observed by watching the **Error** LED turn *On* for a brief period of time.

As previously mentioned, the DTE with TP is automatically performed during the self test sequence for the DSU 56/64.

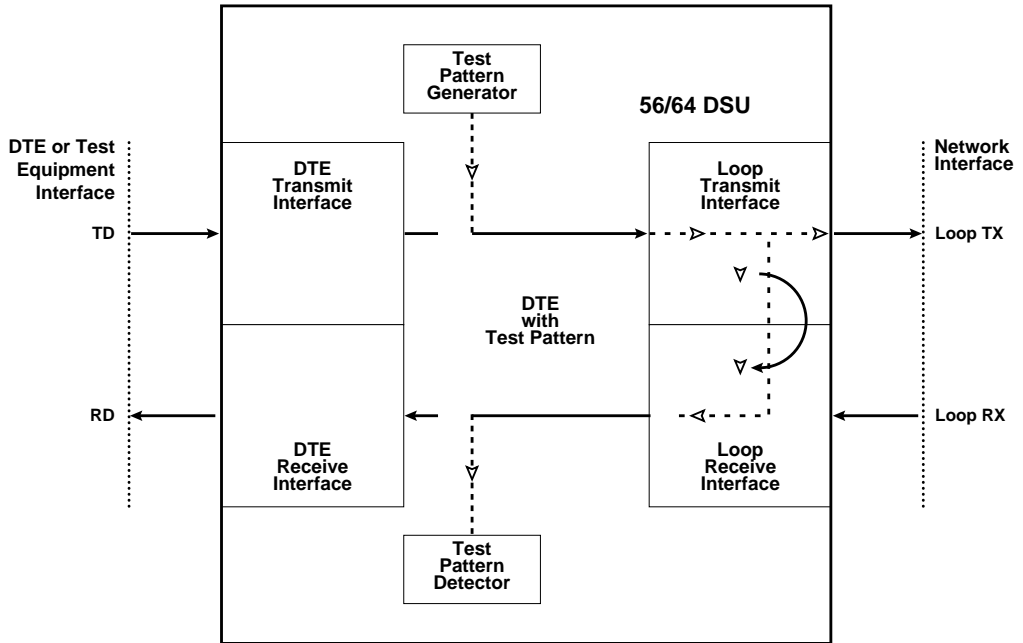

Figure 3-2
DTE with TP Test Diagram

DTE and Loop Test (LL)

This test is initiated at the local DSU 56/64 and allows independent testing of the separate sections of the DSU 56/64. Testing includes testing of the local DTE interface with data from the terminal or test equipment and testing of the loop interface section of the local DSU 56/64 from the remote site over the actual communications circuit. Testing from the remote end of the circuit is performed with test data generated by the remote DSU or terminal type test equipment.

The DTE and Loop test splits the DSU 56/64 into separate DTE and Loop interface sections and then loops the transmit data of each interface back to its respective receive data. Figure 3-3 illustrates the loopback points and the signal paths for this test. The DTE and Loop LEDs *Flash* during initialization of the test and turn *On* solid once the test is in progress.

To initiate the DTE and Loop test, perform the following steps:

1. Press **Select** three times to turn *On* both the **DTE** and **Loop** test indicators.
2. Press **Test** while these test indicators are *On*.

To terminate this test, press **Test**.

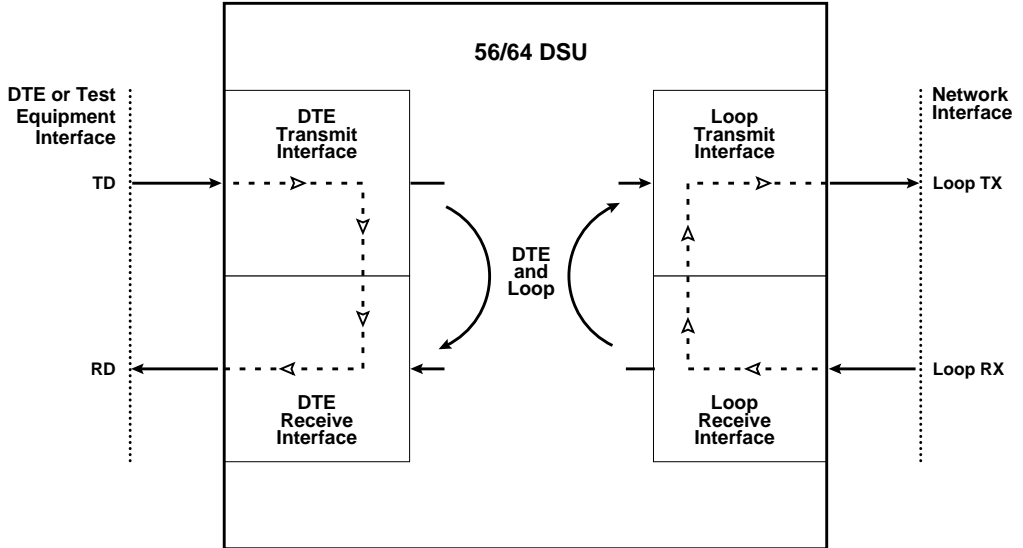

Figure 3-3
DTE and Loop Test Diagram

Loop Only Test

The Loop Only test is used to test the loop interface and a major portion of the DTE interface of the local DSU 56/64 from the remote site over the actual digital data circuit.

For the Loop Only test, the network receive data is looped to the network transmit data inside the DTE interface section of the DSU 56/64. The physical DTE interface is ignored for this test. The Loop LED *Flashes* during initialization of the test and turns *On* solid once the test is in progress. Figure 3-4 is a block diagram illustrating the loopback point and the signal paths for this test.

To initiate the Loop Only test, perform the following steps:

1. Press **Select** four times to turn *On* the Loop test indicator.
2. Press **Test** while this test indicator is *On*.

To terminate this test, press **Test**.

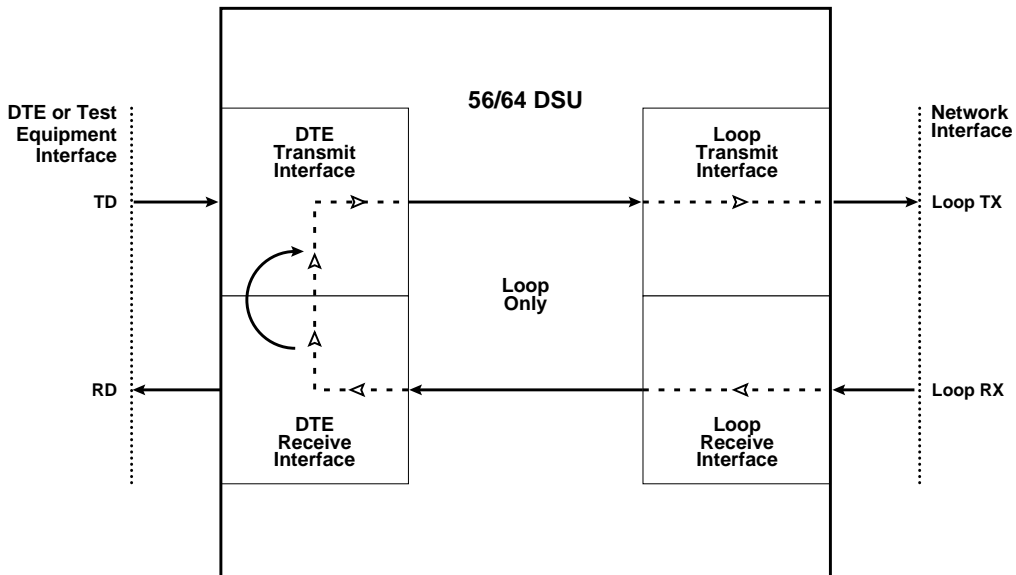

Figure 3-4
Loop Only Test Diagram

FAR END TESTS

Remote Digital Loopback (RDL)

When the **RDL** test is initiated at the local DSU 56/64, it commands the remote DSU into loopback with the industry standard V.54 loopback pattern. The loopback point and the signal paths for the remote DSU are the same as the Loop Only test for a local DSU, shown in Figure 3-4. This loopback test is performed with data from the terminal or test equipment. The RDL LED *Flashes* during initialization of the test and turns *On* solid once the test is in progress.

To initiate the **RDL** test, perform the following steps:

1. Press **Select** five times to turn *On* the **RDL** test indicator.
2. Press **Test** while this test indicator is *On*.

To terminate this test, press **Test**.

RDL with Test Pattern (TP)

When the RDL with TP test is initiated at the local DSU 56/64, the local DSU commands the remote DSU into loopback with the industry standard V.54 loopback pattern. The loopback point and the signal paths for the remote DSU are the same as the Loop Only test for a local DSU; see Figure 3-4. This loopback test is performed with data from the internal test pattern generator and error detector. The RDL and PTRN LEDs *Flash* during initialization of the test and turn *On* solid once the test is in progress.

To initiate the RDL with TP test, perform the following steps:

1. Press **Select** six times to turn *On* both the **RDL** and **PTRN** test indicators.
2. Press **Test** while these test indicators are *On*.

To terminate this test, press the **Test** switch.

Test Pattern (PTRN)

When the **PTRN** test is initiated, the local DSU 56/64 uses the integral test pattern generator to transmit a standard 2047 test pattern to the DSU on the far end of the circuit. The local DSU 56/64 then examines the received data for the standard 2047 pattern. Once this pattern is detected and synchronization is achieved, the **Error** indicator is turned *Off*. The **Error** indicator turns *On* when errors in the receive data pattern are detected. While this test is active, errors can be injected into the transmit data stream by pressing the **Test** push-button. The PTRN LED *Flashes* during initialization of the test and turns *On* solid once the test is in progress.

To initiate the **PTRN** test, perform the following steps:

1. Press **Select** seven times to turn *On* the PTRN test indicator.
2. Press the **Test** switch while this test indicator is *On*.

To terminate this test, press **Test**.

REMOTE TESTS

The DSU 56/64 responds to three remotely activated tests.

- Remote Digital Loopback (RDL)
- CSU Loopback (LL)
- DSU Loopback (RT)

The RDL test is initiated by a remote DSU and causes the local DSU 56/64 to loopback. The loopback point is the same as the Loop Only point. See Figure 3-4. This test is run to test the end-to-end performance of the circuit.

Both the CSU Loopback and the DSU Loopback tests are activated from the telephone company diagnostic test equipment and are used to isolate trouble on a circuit.

The CSU Loopback, commonly called the LL test, has the same loopback points as the DTE and Loop test. It is used by the telephone company to test the integrity of the local loop.

The DSU Loopback, commonly called the RT test, has the same loopback point as the Loop Only test and is used by the telephone company to test the operation of both the local loop and DTE interface sections.

Chapter 4

Specifications Summary

SPECIFICATIONS AND FEATURES

This section describes the standard specifications and features incorporated in the DSU 56/64.

Loop Interface

4-wire, full duplex

Line Requirements

Local loop specifications per AT&T Pub 62310

Loop Rates

56 kbps or 64 kbps

Receiver Sensitivity

-45 dB

DTE Interfaces

V.35 synchronous

DTE Operating Modes

Full or half duplex

DTE Data Rates

56 kbps or 64 kbps synchronous

Diagnostics

- Network test center activated:
 - CSU loopback on sealing current reversal in local loop
 - DSU loopback

- User activated:
 - Self test
 - Local loopback
 - V.54 activated remote loopback with:
 - 2047 test pattern
 - DTE data/data from external test set

Power

115 VAC

4 Watts (maximum)

Environment

- Temperature
 - Operating 0°C to 50°C (32°F to 122°F)
 - Storage -20°C to 70°C (-4°F to 158°F)

- Relative Humidity up to 95%, non-condensing

Index

A

ALM 3
antistream 10

C

Carrier Detect 3
carrier detect 11
CD Indicator 3
Clear To Send 3
clear to send 10
clear to send delay 10
configuration 10
 antistream 10
 carrier detect 11
 clear to send 10
 clear to send delay 10
 data set ready 11
 rate 12
 remote digital loopback 11
 scrambler 12
CS Indicator 3
customer service 9

D

data set ready 11
description 1
DIP switch 5, 10
DTE 3

DTE connections 13
DTE data rates 27
DTE interface 27
DTE status 3

E

Emissions Requirements iv
environment 28
error 4

F

far end tests 23
 RDL with TP 23
 remote digital loopback 23
 test pattern (PTRN) 24
front panel 3

I

Indicator
 CD 3
 CS 3
 RD 3
 RS 3
 TD 3

L

LED identification 3
line requirements 27

loop 3
 interface 27
 rate 27
 service rates 1
loop rate 12

N

near end tests 16
 DTE and loop test 20
 DTE only test 16
 DTE with TP 17
 loop only test 22
network connections 13
 DTE connector 13
network status 3

O

options 5

P

power 28
power up 8
primary V.35 5, 13
PTRN 4

R

RD Indicator 3
RDL 4
rear panel 5
Receive Data 3
receiver sensitivity 27
receiving inspection 7
remote digital loopback 11
remotely activated tests 25
 remote digital loopback 25
Request To Send 3
return material authorization 9
RS Indicator 3

S

scrambler 12
select 4
select switch 4
self test 15
switches
 DIP 5, 10
 select 4

T

TD Indicator 3
telco 5
test status 3
test switches 4
Transmit Data 3

W

warranty 9

Product Support Information

Presales Inquiries and Applications Support

Please contact your local distributor, ADTRAN Applications Engineering, or ADTRAN Sales:

Applications Engineering (800) 615-1176
Sales (800) 827-0807

Post-Sale Support

Please contact your local distributor first. If your local distributor cannot help, please contact ADTRAN Technical Support and have the unit serial number available.

Technical Support (888) 4ADTRAN

Repair and Return

If ADTRAN Technical Support determines that a repair is needed, Technical Support will coordinate with the Return Material Authorization (RMA) department to issue an RMA number. For information regarding equipment currently in house or possible fees associated with repair, contact RMA directly at the following number:

RMA Department (205) 963-8722

Identify the RMA number clearly on the package (below address), and return to the following address:

ADTRAN, Inc.
RMA Department
901 Explorer Boulevard
Huntsville, Alabama 35806

RMA # _____