

FrameSaver™ ISDN Dial Backup Module (DBM) Installation Instructions

Document Number 9000-A2-GN19-60

Feature Number 9098-F1-870 (BRI) and 9098-F1-875 (PRI)

February 1999

Product Documentation on the World Wide Web

We provide complete product documentation online. This lets you search the documentation for specific topics and print only what you need, reducing the waste of surplus printing. It also helps us maintain competitive prices for our products.

Complete documentation for this product is available at www.paradyne.com.
Select *Service & Support* → *Technical Manuals* → *FrameSaver Frame Relay Devices*.

Select one of the following documents:

9121-A2-GH30

FrameSaver 9120 Technical Reference

9128-A2-GB20

FrameSaver SLV 9126/9128 User's Guide

9621-A2-GH30

FrameSaver 9620 Technical Reference

To request a paper copy of a Paradyne document:

- Within the U.S.A., call 1-800-PARADYNE (1-800-727-2396)
- Outside the U.S.A., call 1-727-530-8623

To order the 9120 Technical Reference, request Feature Number 9120-M1-001.

To order the 9126/9128 User's Guide, request Feature Number 9128-M1-001.

To order the 9620 Technical Reference, request Feature Number 9620-M1-001.

Before You Begin

Make sure you have:

- One of the following ISDN services ordered and installed
 - BRI Service: Capability Package B for 1B-channel service, or Capability Package I for 2B-channel support, NI-1 (supporting up to two B-channels)
 - PRI Service: PRI, NI-2, AT&T 4ESS, or AT&T 5ESS custom (supporting up to 23 B-channels), with Circuit-Switched Data capability.

- One of the following ISDN cables (20 feet – 6.1 meters).
 - BRI: RJ49C ISDN-U cable if a FrameSaver 9126 with an ISDN BRI DBM.
 - PRI: RJ48C cable if a FrameSaver 9128 with an ISDN PRI DBM.
- Configuration information for the FrameSaver unit and the DBM.
 - Local phone number for the DBM.
 - SPIDs (service profile IDs) for a BRI DBM.
 - Outbound Phone Number for the calling unit.
 - CNIS (calling number identification service) and Inbound Calling IDs for the answering unit.
- Tools:
 - 1-Slot unit: Small flat-blade screwdriver and small Phillips screwdriver.
 - Multislot unit: Phillips screwdriver.

Package Checklist

Verify that your package contains the following:

- Dial Backup Module (DBM)
- Standoff posts, washers, and screws:
 - BRI DBM: Two standoff posts, four washers, and four Phillips-head screws
 - PRI DBM: Three standoff posts, six washers, and six Phillips-head screws

Safety Instructions

Please read the EMI warnings and Important Safety Instructions that come with the FrameSaver unit.

⚠ HANDLING PRECAUTIONS FOR STATIC-SENSITIVE DEVICES

This product is designed to protect sensitive components from damage due to electrostatic discharge (ESD) during normal operation. When performing installation procedures, however, take proper static control precautions to prevent damage to equipment. If you are not sure of the proper static control precautions, contact your nearest sales or service representative.

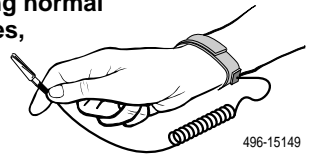

496-15149

Before upgrading a NAM with the DBM feature, or replacing either, locate or record the FrameSaver unit's configuration options, or transfer the configuration using the FTP (file transfer protocol) feature (refer to the User's Guide or Technical Reference). This may be useful when setting up again, verifying operation, or troubleshooting.

Removing the NAM from Its Housing

Select the appropriate procedure for removing the NAM from its housing. See page 4 if the NAM is in a multislotted housing.

Removing the NAM from a 1-Slot Housing

1. Disconnect the power cord/transformer, first from the power outlet, then from the rear of the FrameSaver unit.
2. Disconnect the other cables.

3. Using a small flat-blade screwdriver, gently pry open the housing at each of the four connecting tab points. Be careful not to damage the housing (using a screwdriver that is too big could damage the housing.)

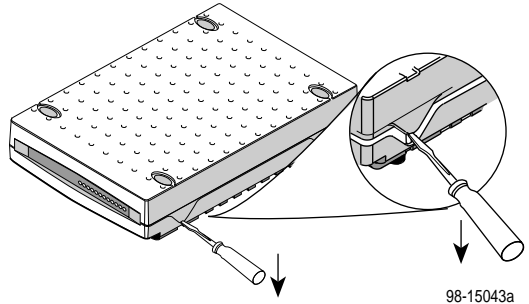

4. Remove the cover and lift the NAM and its integrated I/O card/backplane (rear panel) from the base.

5. Lay the NAM on an electrostatic discharge-protective work surface, component side up, with the card connectors on the left-hand side.

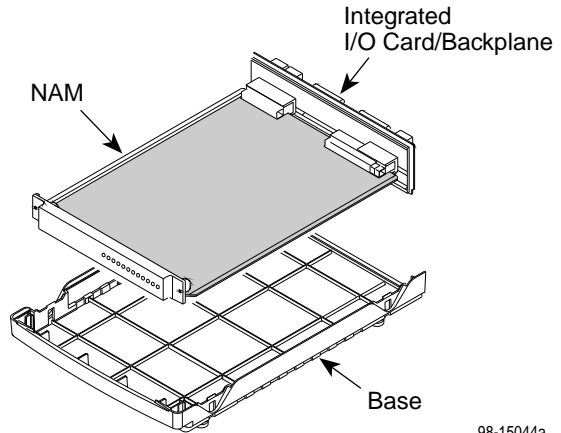

Removing the NAM from a Multislot Housing

The illustration shows the 14-slot access carrier as the housing.

1. Unscrew the captive screws from the ejector latches on front of the carrier.
2. Press open the ejector latches to disengage the card.
3. Supporting the card by its edges, pull straight out until the card clears the carrier.
4. Lay the NAM on an electrostatic discharge-protective work surface, component side up, with the card connectors on the left-hand side.

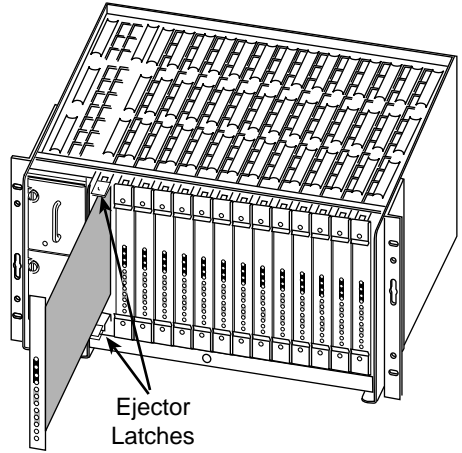

Front View

98-16209

Proceed to *Removing a DBM* on page 5 if transferring a DBM to another NAM or replacing a DBM. Otherwise, proceed to *Installing a DBM* on page 6.

Removing a DBM

1. Remove the screws and washers from the standoff posts that hold the DBM to the NAM, and set them aside.
 - For a BRI DBM, there are two sets of screws, washers, and standoff posts to be removed.
 - For a PRI DBM, there are three sets of screws, washers, and standoff posts to be removed.

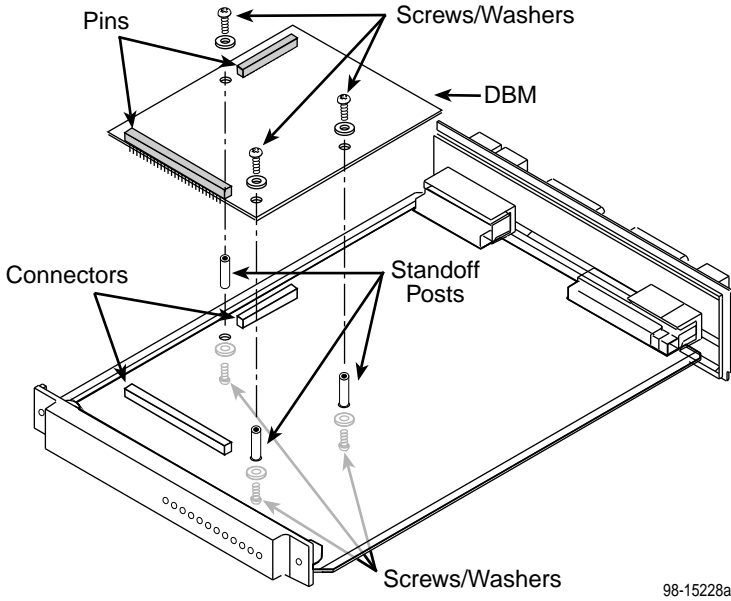

98-15228a

2. Turn the NAM over and remove the screws and washers on the underside of the NAM, and set the standoff posts, screws, and washers aside.
3. Turn the NAM over again so the DBM is on top.
4. Work the DBM away from the NAM by very carefully and gently pulling and rocking the DBM connectors away from the NAM connectors. Work first from one side, then the other until the DBM is free. **Be careful not to bend any pins.**

Installing a DBM

Refer to the illustration on page 5 when following this procedure.

1. Remove the DBM, standoff posts, screws and washers from the shipping box.
2. Position a standoff post at one of the holes in the NAM, put a screw through a washer, insert the screw from the underside of the NAM, and tighten the screw to hold the standoff post in place.
 - For a BRI DBM, there are two holes in the NAM and two sets of screws, washers, and standoff posts.
 - For a PRI DBM, there are three holes in the NAM and three sets of screws, washers, and standoff posts.
3. Install the other standoff post(s) in the same way.
4. Hold the DBM, pin side down, so the two sets of pins are aligned with their respective connectors. Carefully match the pins to the holes of the two connectors.
5. Press the pins and connectors together until both pin sets are firmly seated.
Be careful not to force or bend any pins.
6. Insert the remaining screws and washers into the standoff post holes on the DBM, and tighten.

Reinstalling the NAM

Select the appropriate procedure for reinstalling the NAM in its housing.

Reinstalling the NAM in a 1-Slot Housing

Refer to the illustrations on page 3, if necessary.

1. Reinstall the NAM in its housing, snapping the cover and base together at each of the four connecting tab points.
2. Reconnect the cables.

Reinstalling the NAM in a Multislot Housing

Refer to the illustration on page 4, if necessary.

1. Align the NAM with the upper and lower tracks of the slot.
2. Slide forward until the NAM seats. Be careful not to force or bend any pins.
3. Close both the upper and lower ejector latches on the carrier to lock in place, then tighten the captive screws.

Installing the ISDN Cable

Select the appropriate procedure for the DBM being installed.

Installing a BRI Cable

1. Insert the 8-pin connector on the ISDN-U cable into the DBM interface (or BKP interface on a FrameSaver 9620).
2. Insert the other end of the cable into the ISDN service RJ49C jack.
3. Reconnect the power cord, first to the rear of the FrameSaver unit, then to the power outlet.

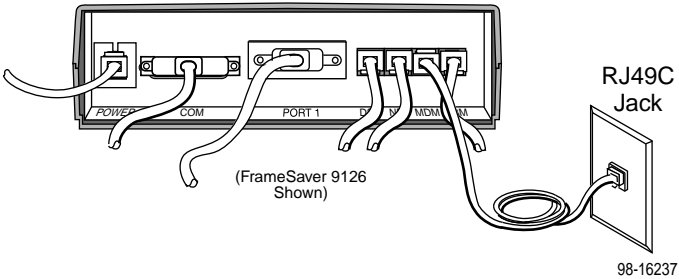

Installing a PRI Cable

1. Insert the 8-pin connector on the ISDN cable into the DBM interface.
2. Insert the other end of the cable into the ISDN service RJ48C jack.

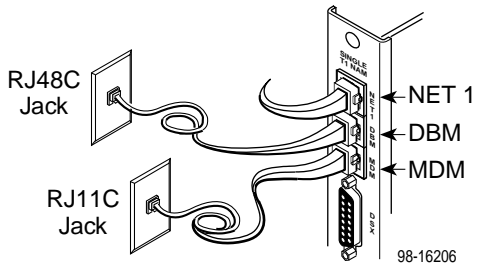

Setting Up the DBM

Once the DBM is installed, it must be set up for dial backup. Another DBM must be installed at the far end before backup can take place.

The DBM at one end of the link must be set up to place a call when there is a failure and the other DBM must be configured to answer the call. The recommended method is for remote sites to place the calls (usually with BRI DBMs) and for the central site to answer calls (usually with a PRI DBM).

The following guidelines apply.

- Central site configuration guidelines:
 - Configure a Link Profile for each remote site.
 - Configure the unit to answer calls from the remote sites.
 - Leave Automatic Backup Configuration disabled.
 - Manually create alternate DLCIs on the ISDN Backup Link.
 - Manually specify ISDN DLCIs as alternate DLCIs for the PVC Connection after the primary DLCIs have been automatically discovered from the primary network Link LMI or manually configured.
- Remote site configuration guidelines:
 - Configure a Link Profile for the central site in the first link profile, called HQ_Site. This ensures that a backup DLCI will be created automatically on the backup link for each DLCI discovered on the network interface using the central site's link profile.
 - Configure the unit to originate calls to the central site if it is a FrameSaver 9128. A FrameSaver 9126 is already configured to originate calls.
 - Enable the Automatic Backup Configuration feature if the unit is a FrameSaver 9128. A FrameSaver 9126 already has this feature enabled.

To set up the DBM for dial backup:

1. Configure the DBM interface.

Main Menu → Configuration → ISDN → Physical

2. Minimally, set the following configuration options:
 - Interface Status is set to Enable.
 - Originate or Answer is set to Answer for a central site, and set to Originate for a remote site.
 - Local Phone Number 1 is entered, plus the following:

FrameSaver 9126 with BRI	FrameSaver 9128 with PRI
Configure the B-channels: <ul style="list-style-type: none">■ Service Profile ID1 (SPID)■ Local Phone Number 1■ Service Profile ID2 (SPID)■ Local Phone Number 2	Configure T1 physical characteristics to match the service provider's settings. <ul style="list-style-type: none">■ Local Phone Number

3. Save the configuration and return to the ISDN menu.
4. Select Link Profiles, then type **n** (New) and press Enter.
5. Set up the ISDN Link Profiles.
 - Name for the destination entered (e.g., Tampa). The default setting is HQ_Site.
 - Link Status is set to Auto.
 - Phone numbers entered:

Originating FrameSaver Unit	Answering FrameSaver Unit
Outbound Phone number. Valid characters can include: <ul style="list-style-type: none"> ■ Numbers (0–9) ■ Special characters * and # ■ Spaces 	Inbound Calling ID1 and ID2. These are the phone numbers of units that calls will be accepted from. Valid characters can include: <ul style="list-style-type: none"> ■ Numbers (0–9)

Remember to include local dial-out numbers (i.e., 9, then the number).

6. If configuring a central site unit proceed to Step 11.
If configuring a remote site unit, proceed to Step 11.
7. Save the configuration and return to the ISDN menu.
8. Select DLCI Records, New, and press Enter. Minimally, configure the following options to create DLCI records for the link:
 - DLCI number
 - DLCI Type is set to Multiplexed if a multiplexed DLCI is being backed up.
9. Save the configuration and return to the Configuration Edit/Display menu.
10. Select PVC Connections, then New. Minimally, configure the following options to create a PVC connection to be backed up.
 - Alternate Destination Link name entered (e.g., Tampa). See the ISDN Link Profile Name.
 - Alternate Destination DLCI.
 - Alternate Destination EDLCI if a multiplexed DLCI.
11. Save the configuration and return to the Configuration Edit/Display menu.
12. Select Auto Backup Criteria.
13. Enable Auto Backup.
14. Specify When Auto Backup Allowed – Always or Restrict. If Restrict is selected, specify the days and hours of the week during which automatic backup can take place.
15. Save the change and return to the Configuration Edit/Display menu.

See *Setting Up An ISDN DBM for Dial Backup* in *Setup* of the User's Guide for additional information.

Verification Checklist

- Verify the ISDN lines by checking the DBM Interface Status.

Main Menu → Status → DBM Interface Status

- If Line Status displays Active, the ISDN line is operational.
- If Line Status displays an invalid (Inv) status (e.g., Inv SPID), verify that you entered ISDN physical options correctly.

- Check backup setup.

- Disconnect the network cable at the remote site.
- Check the status of the FrameSaver unit:

Main Menu → Status → System and Test Status → Health and Status column

- Wait as the originating DBM places the backup call.
The originating unit BKP LED starts blinking.

When the answering FrameSaver unit receives the call, its BKP LED starts blinking, and the **ISDN Active** message appears.

The BKP LEDs of both units stop blinking and remain on when the connection is made, and the **Backup Active** message appears.

- Verify that data is passing between DBMs by selecting a backup link.

Main Menu → Status → Performance Statistics → Frame Relay

If data is being passed, Frames/Characters Sent and Received (Frame Relay Link) and Status Msg Received (Frame Relay LMI) increment each time the screen is Refreshed.

A PVC Connectivity test can also be run if the ISDN DLCI is multiplexed.

Main Menu → Test → ISDN PVC Tests → [DLCI Number] → Connectivity → Start

See the User's Guide or Technical Reference for additional information.

Setting Up Automatic Backup Configuration

Only applicable to a FrameSaver 9126 or 9128, the Automatic Backup Configuration feature is used to automatically create alternate DLCI records and PVC connections on the ISDN DBM (backup) interface when there is a failure of the primary link or DLCI, or LMI is Inactive. This feature should be disabled for the central site unit, but enabled for the remote unit.

Automatic backup can be changed at any time via the Auto Backup Criteria configuration options. Specific days and times that backup will be allowed can also be specified. The following table describes what happens when Auto Backup is enabled or disabled.

Auto Backup	Description
Enable	Auto-configuration of backup is enabled and traffic is rerouted to the backup (alternate) interface when a failure occurs. The FrameSaver unit automatically enables the Alternate Link configuration option and creates an Alternate DLCI and EDLCI, and traffic is rerouted over the backup interface.
Disable <i>(Default)</i>	Auto-configuration of backup is disabled and traffic is not rerouted to the backup interface.

See *Changing the Automatic Backup Configuration* in *Setup and Configuring Auto Backup Criteria* in *Configuration Options* of the User's Guide for more information.

Faceplate LEDs

The FrameSaver unit's faceplate includes LEDs (light-emitting diodes) that provide status on the FrameSaver unit and its interfaces. In addition, it provides backup status for FrameSaver units equipped with an ISDN DBM.

See the BKP (backup) and ALM (alarm) LEDs when verifying DBM setup and operation. For additional LED information, see the User's Guide.

Label	Indication	Color	What It Means
OK	Power and Operational Status	Green	ON – FrameSaver unit has power and is operational. OFF – FrameSaver unit is in a power-up self-test, or there is a failure.
ALM	Operational Alarm (Fail)	Red	ON – FrameSaver unit has just been reset, or an error or fault has been detected. OFF – No failures have been detected.
TST	Test Mode	Yellow	ON – Loopback or test pattern in progress, initiated locally, remotely, or from the network. OFF – No tests are active.
BKP ¹	Backup	Yellow	ON – FrameSaver unit is in Backup mode; that is, the backup link has been established, and backup is in progress through the specified Alternate Destination Link. OFF – FrameSaver unit is not in Backup mode. Blinking ON and OFF (Rate: 1 Hz) – Alternate Destination Link is being established, but no data has been passed.

¹ When an ISDN BRI DBM is installed, if the OK LED comes on during power recycling, then goes off, the ISDN BRI DBM may have failed.

Technical Specifications

Specification	Criteria
ISDN BRI DBM	
ISDN BRI DBM Interface (FrameSaver 9126) Physical interface Service supported Data rates	ISDN BRI U-interface: One 8-position modular keyed USOC RJ49C jack RJ49C Capability Package B for 1B-channel service, or Capability Package I for 2B-channel support, NI-1 (supporting up to two B-channels) 56 kbps and 64 kbps
Standards Compliance	ANSI T1.601 – 1992 (physical layer) Bellcore SR-NWT-001937, Issue 1 – February 1991 ITU Q.921 – 1992 (link layer) ITU Q.931 – 1993 (network layer) TR-TSY-00860, ISDN Calling Number Identification Services – February 1989, and Supplement – June 1990
Power Consumption	60 mA at 15 Vdc Average power .9 watt
Weight	0.27 lbs. 4.3 oz. (0.12 kg 122 grams)
Switch Compatibility	National ISDN-1 (NI-1)
Switched Network Interface	One USOC RJ45 8-pole keyed modular plug and jack, specified in ISO/IEC 8877
Transmit Interface Signal Level Impedance	13.5 dBm nominal over frequency band, 0 Hz – 80 kHz 135 Ω
Receive Interface Dynamic Range Impedance	Operates on 2-wire loops, defined in ANSI T1.601-1992 135 Ω
Modulation and Frequency	2B1Q line coding with 4-level amplitude modulation (PAM) at 80 kbps
Channel Equalization Receiver	Automatic adaptive equalizer with echo cancellation

Specification	Criteria
ISDN PRI DBM	
ISDN PRI DBM Interface (FrameSaver 9128)	8-position modular unkeyed USOC RJ48C jack
Physical interface	RJ48C
Service supported	PRI, NI-2, ATT 4ESS, or ATT 5ESS custom (supporting up to 23 B-channels), with Circuit-Switched Data capability.
Data rates	1.536 kbps
Framing format	D4, ESF
Coding format	B8ZS
Line Build-Out (LBO)	0.0 dB, -7.5 dB, -15 dB, -22.5 dB
ANSI PRM	Selectable
Standards Compliance	ANSI T1.403 – 1989 (physical layer) and AT&T 62411 Bellcore SR-NWT-002120, Issue 1 – May 1992 ITU Q.921 – 1992 (link layer) ITU Q.931 – 1993 (network layer) TR-TSY-00860, ISDN Calling Number Identification Services – February 1989, and Supplement – June 1990
Power Consumption	8 mA at 120 Vac Average power 1 watt
Weight	0.15 lbs. 2.4 oz. (0.07 kg 68 grams)
Switch Compatibility	National ISDN-2 (NI-2), ATT 4ESS, or ATT 5ESS
Framing Format	D4, ESF
Coding Format	B8ZS
Line Build-Out (LBO)	0.0 dB, -7.5 dB, -15 dB, -22.5 dB
ANSI PRM	Selectable

Pin Assignments

Since FrameSaver SLV units use standard connectors, there is no need to order, buy, or make special cables. You can use any standard straight-through cable for the DBM interface.

ISDN BRI/U Interface Pin Assignments

Function	Circuit	Direction	Pin Number
BRI Transmit/Receive Ring	DBM4	To/From Local Loop	4
BRI Transmit/Receive Tip	DBM5	To/From Local Loop	5

ISDN PRI Interface Pin Assignments

Function	Circuit	Direction	Pin Number
PRI Receive Ring	DBM1	From Local Loop	1
PRI Receive Tip	DBM2	From Local Loop	2
PRI Transmit Ring	DBM4	To Local Loop	4
PRI Transmit Tip	DBM5	To Local Loop	5

Warranty, Sales, and Service Information

Contact your local sales representative, service representative, or distributor directly for any help needed. For additional information concerning warranty, sales, service, repair, installation, documentation, training, distributor locations, or Paradyne worldwide office locations, use one of the following methods:

- **Via the Internet:** Visit the Paradyne World Wide Web site at <http://www.paradyne.com>
- **Via Telephone:** Call our automated call system to receive current information via fax or to speak with a company representative.
 - Within the U.S.A., call 1-800-870-2221
 - Outside the U.S.A., call 1-727-530-2340

Document Feedback

We welcome your comments and suggestions about this document. Please mail them to Technical Publications, Paradyne Corporation, 8545 126th Ave. N., Largo, FL 33773, or send e-mail to userdoc@eng.paradyne.com. Include the number and title of this document in your correspondence. Please include your name and phone number if you are willing to provide additional clarification.

Trademarks

All products and services mentioned herein are the trademarks, service marks, registered trademarks or registered service marks of their respective owners.



9000-A2-GN19-60