

FrameSaver 9120 Network Access Module (NAM) Installation Instructions

Document Number 9121-A2-GN10-20

December 1998

Product Documentation on the World Wide Web

We provide complete product documentation online. This lets you search the documentation for specific topics and print only what you need, reducing the waste of surplus printing. It also helps us maintain competitive prices for our products.

Complete documentation for this product is available at www.paradyne.com.
Select *Service & Support* → *Technical Manuals* → *FrameSaver Frame Relay Devices*.

Select the following documents:

9121-A2-GB20

FrameSaver 9120 User's Guide

9121-A2-GH30

FrameSaver 9120 Technical Reference

To request a paper copy of a Paradyne document:

- Within the U.S.A., call 1-800-PARADYNE (1-800-727-2396)
- Outside the U.S.A., call 1-727-530-8623

Before You Begin

Make sure you have:

- A small, flat-blade screwdriver.
- A small, Phillips screwdriver if transferring an ISDN BRI DBM to the new NAM, or if installing the NAM in a FrameSaver 9000 Series Access Carrier.
- 1-Slot Assembled Access Unit Installation Instructions* (Document No. 9000-A2-GN10) to reinstall the access unit once the NAM is installed, if using a 1-slot housing.
- FrameSaver 9000 Series Access Carrier Installation Instructions* (Document No. 9000-A2-GN1D) for power-up verification procedures, if using an access carrier.
- ISDN BRI Dial Backup Module (DBM) Installation Instructions* (Document No. 9000-A2-GN19) to uninstall, then reinstall a DBM if one is currently installed on the NAM being installed or replaced.
- Configuration information for the NAM being installed or replaced.

If an ISDN BRI DBM is installed on a NAM being installed or replaced, the DBM must be uninstalled, then reinstalled onto the replacement NAM.

Package Checklist

Verify that your package contains the following:

- NAM
- NAM I/O card, if installing the NAM in an access carrier
- Appropriate cables
- Ferrite chokes

Safety Instructions

Please read the EMI warning and Important Safety Instructions in the Technical Reference or in the installation instructions that you received with your housing.

⚠ HANDLING PRECAUTIONS FOR STATIC-SENSITIVE DEVICES

This product is designed to protect sensitive components from damage due to electrostatic discharge (ESD) during normal operation. When performing installation procedures, however, take proper static control precautions to prevent damage to equipment. If you are not sure of the proper static control precautions, contact your nearest sales or service representative.



Removing a NAM from a 1-Slot Housing

Before replacing a NAM, locate or record the access unit's configuration options, or transfer the configuration using the FTP (file transfer protocol) feature. This is useful when setting up the replacement NAM, verifying operation, or troubleshooting.

1. Disconnect the power cord/transformer, first from the ac outlet, then from the rear of the access unit.
2. Disconnect the other cables.

3. Open the 1-slot housing using a small flat-blade screwdriver. Gently pry open the housing at each of the four connecting tab points. However, if the screwdriver is too big or you do not open carefully, you could cause damage to the housing.

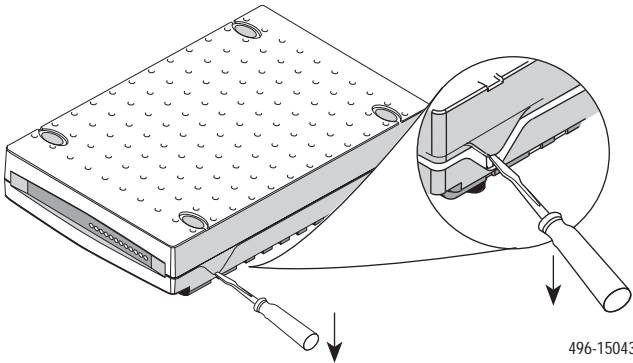

4. Remove the cover.
5. Lift the NAM and the integrated I/O card/backplane (rear panel) from the base.

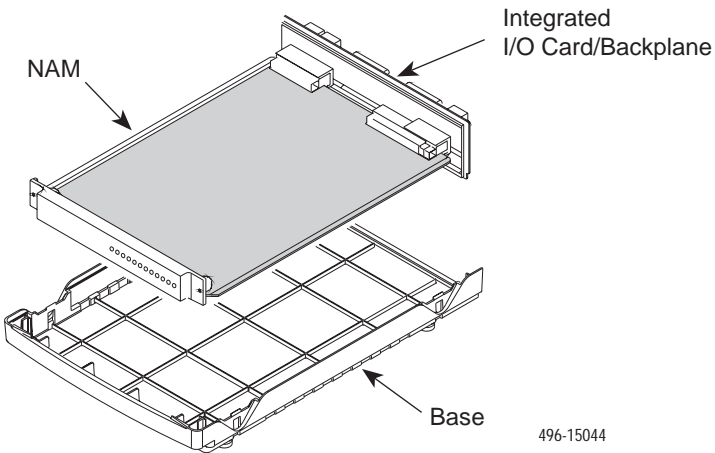

-
6. Work the NAM away from the I/O card (not the backplane, since the backplane might bend) by very carefully and gently pulling and rocking the NAM connectors away from the I/O card connectors. Work first from one side, then the other, until the NAM is separated from the I/O card. Set the NAM aside.

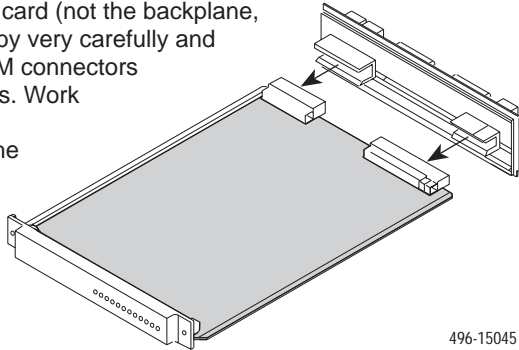

496-15045

If an ISDN BRI DBM is Installed

1. Remove the DBM from the NAM being replaced.
2. Reinstall the DBM onto the replacement NAM.

Refer to the *ISDN BRI Dial Backup Module (DBM) Installation Instructions* to uninstall and reinstall the DBM.

Installing a NAM in a 1-Slot Housing

1. Remove the NAM from its shipping box.
2. Carefully align the NAM connectors with the integrated I/O card/backplane (rear panel) connectors. (See Step 3 of *Removing a NAM from a 1-Slot Housing* on page 2 if you need to open the housing first.)

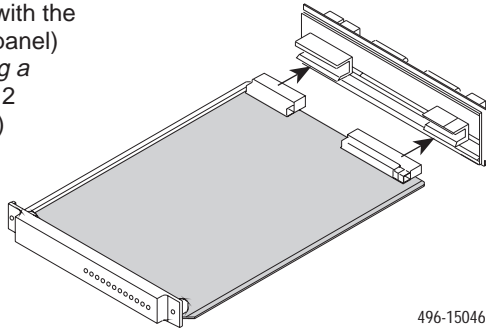

3. Gently, but firmly press the connectors together until they are fully seated. Be careful not to force or bend any pins.

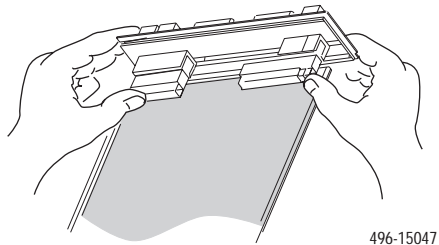

4. Place the NAM and integrated I/O card/backplane into the 1-slot housing's base. Make sure the backplane rests inside the guides on the base at the rear of the access unit.

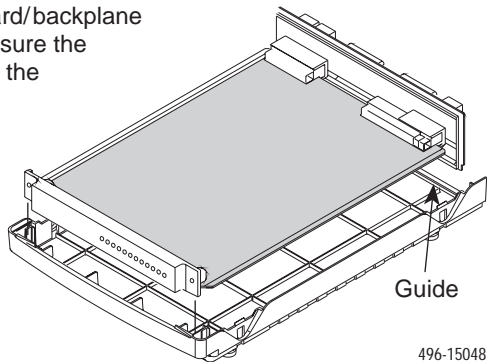

5. Place the cover over the base, aligning the four connecting tabs. Make sure the backplane rests inside the guides on the cover at the rear of the access unit.
6. Press the cover and base together until all four connecting tabs snap into place.
7. Reconnect the power cord/transformer, verifying that the faceplate's OK LED lights once the self-test is passed.
Refer to the *1-Slot Assembled Access Unit Installation Instructions* before reinstalling the cables.

Recommended Order for Installing a NAM into an Access Carrier

1. Install the I/O card.
2. Connect all cables into the I/O card.
3. Install the NAM.
4. Go to the *FrameSaver 9000 Series Access Carrier Installation Instructions* for power-up verification procedures.

Installing the I/O Card into the Access Carrier

The NAM's I/O card provides the COM port, network, DSX, and DTE connections. The I/O card inserts directly behind the NAM that it supports.

1. Remove the I/O card from the shipping box. Handle only by the top and bottom edges to avoid damaging the card.
2. At the rear of the carrier, align the I/O card with the upper and lower tracks of the slot. Push gently towards the midplane until it stops and you cannot push the card any further.

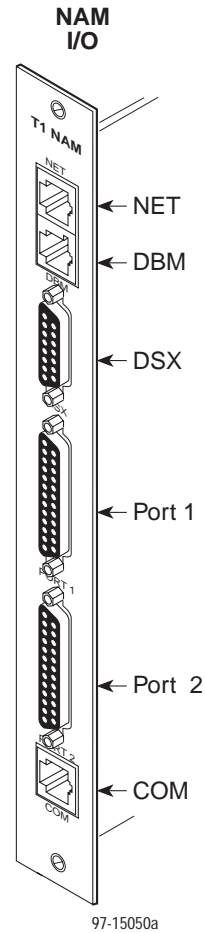
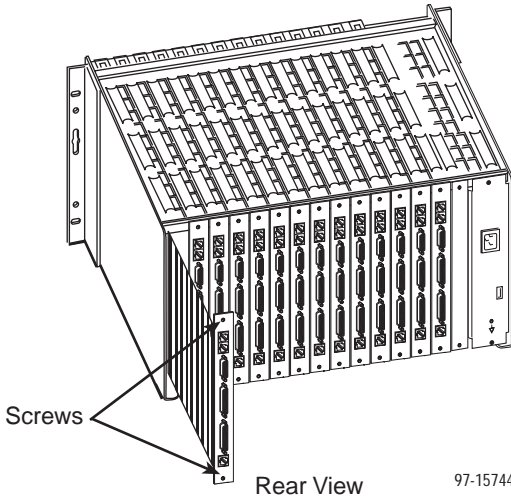

3. There are two captive screws on the I/O card. Using a screwdriver, alternately tighten each screw until the screws are all the way in.

Connecting to the Network

1. Insert the 8-pin connector on the RJ48C network cable into the NET interface.
2. Insert the other end of the cable into the RJ48C modular jack.

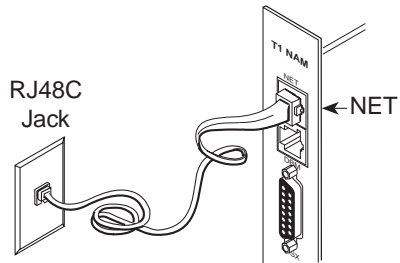

97-15053-01

Connecting to an M66 Block

Use the optional T1 mass termination cable to connect up to seven NAMs to an M66 block. The T1 mass termination cable is a 5-foot RJ48H cable consisting of a 50-pin plug-to-seven RJ48C plugs. See the RJ48H Connector for T1 Mass Termination Cable table on page 22 for pin assignments.

1. Insert up to seven of the RJ48C plugs on the RJ48H network cable into the NET interface(s).
2. Insert the 50-pin plug end of the cable into the M66 block.

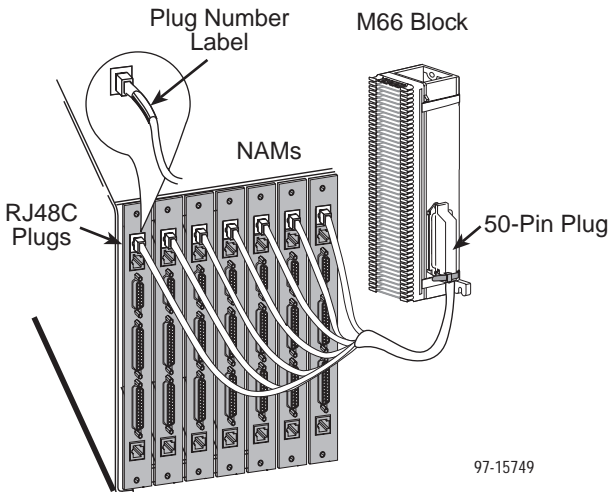

97-15749

Connecting to a DTE

If the DTE cable type is V.35, RS449, or V.11/X.21 (separately orderable):

1. Connect the plug to the V.35, RS449, or V.11/X.21 end of the adapter cable (as appropriate).
2. Connect the EIA-530A end of the adapter cable to PORT 1 or PORT 2.

If the DTE cable type is EIA-232E or 530A:

1. Connect the EIA-232E or EIA-530A end of the DTE cable to PORT 1 or PORT 2.

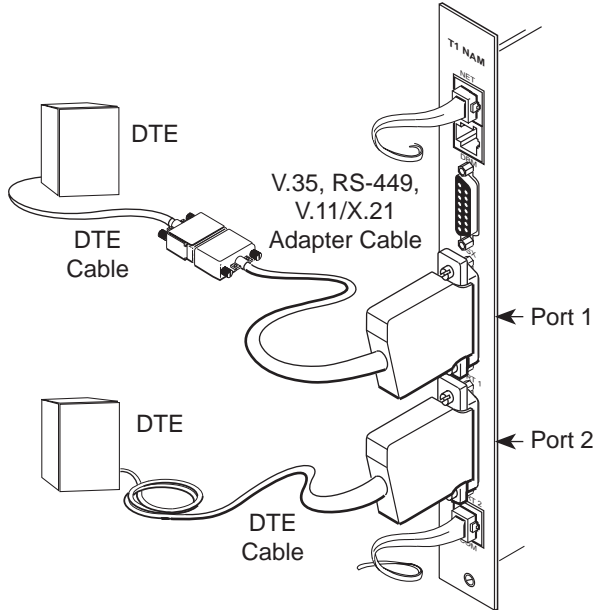

97-15054-01

Connecting to the DSX

1. Insert the DB15 end of the DSX cable into the DSX interface.
2. Insert the other end of the cable into the FCC Part 68 Registered CPE (Customer Premises Equipment, such as a PBX).

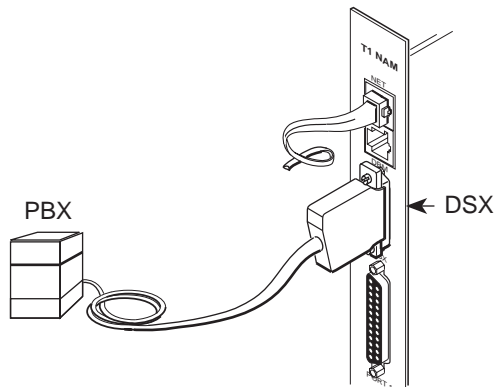

97-15055-01

Installing the Ferrite Choke

Two ferrite chokes are supplied with the FrameSaver T1 Frame Relay NAM. You must install a ferrite choke on each DTE cable that you connect to Port 1 and/or Port 2 on the NAM I/O if the interface type is one of the following:

- EIA-530A
- RS449
- V.11/X.21
- V.35

CAUTION:

All supplied ferrite chokes must be installed following these instructions to ensure compliance with regulatory rules.

1. Open the ferrite choke and place it around the cable as close to the cable connector as possible. **The ferrite choke must be installed on the cable that attaches directly to Port 1 or Port 2 on the T1 Frame Relay NAM I/O.**
2. Close the two halves around the cable and snap the choke shut, pressing down on the plastic latch to secure it in place.

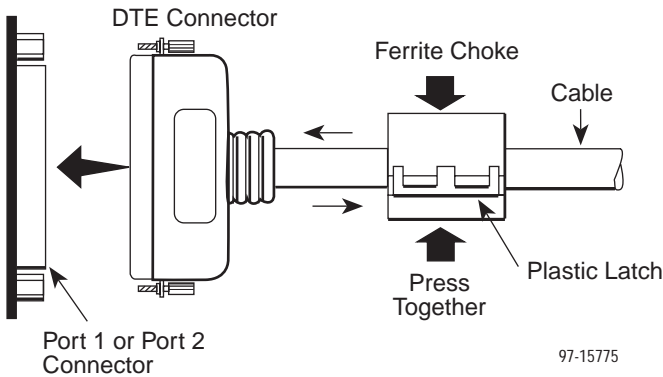

97-15775

Connecting the COM Port to a User Interface

1. Insert the 8-pin end of the cable into the COM port.
2. Insert the other end of the cable into the user interface (VT100-compatible terminal emulation) connector.

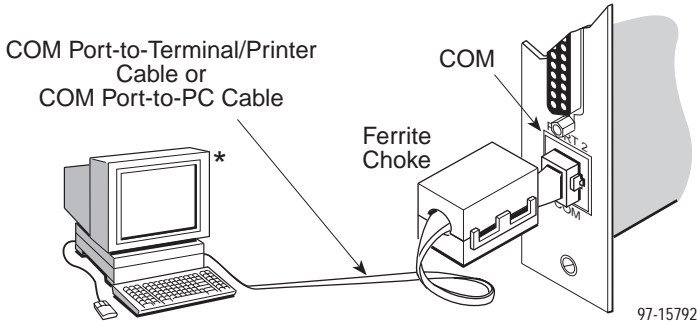

* Set the speed of the async (VT100-compatible) terminal so it matches the NAM's factory-loaded data rate of 19.2 kbps, character length set to 8, parity set to None, and stop bits set to 1. The flow control should be set to None or Hardware.

3. Install the supplied ferrite choke on the COM port cable. To do this, open the ferrite choke and place it as close to the cable connector as possible. Then, close the two halves around the cable and snap the choke shut, pressing down on the plastic latch to secure it in place.
4. Press Return on the keyboard to display the Main Menu. If you need to configure for other than a direct link, see the Technical Reference.

Installing the ISDN-U Cable (if an ISDN BRI DBM is installed)

1. Insert the 8-pin connector on the ISDN-U cable into the DBM interface.
2. Insert the other end of the cable into the ISDN service RJ49C jack.
3. Reconnect the power cord, first to the rear of the access unit, then to the power outlet.

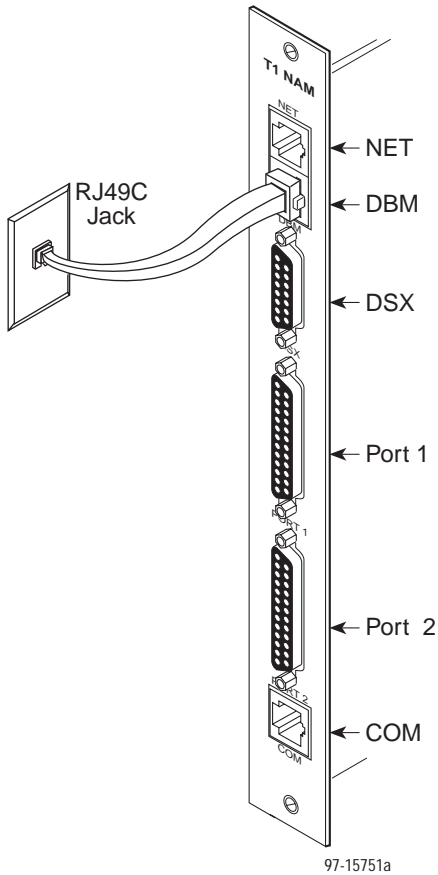

Installing the NAM into the Access Carrier

CAUTION:

Be sure that you install the NAM in the correct slot so that it mates with its matching I/O card. Otherwise, you could damage your card.

1. Remove the NAM from the shipping box. Handle only by the top and bottom edges to avoid damaging the card.
2. At the front of the carrier, align the NAM with the upper and lower tracks of the appropriate slot.

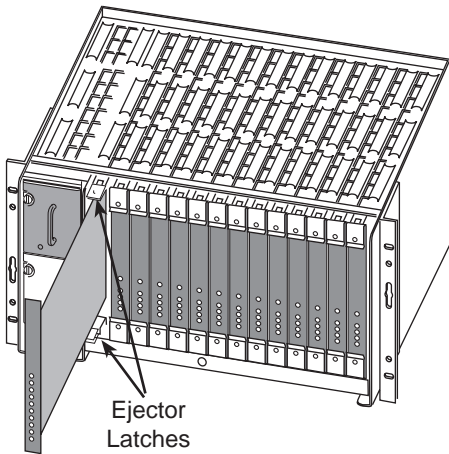

Front View

97-15754

3. Slide the NAM into the tracks until it seats with the midplane connectors. Use care not to force the card or bend any pins.
4. Close both the upper and lower ejector latches on the carrier to lock in the card place, then tighten the captive screws on the ejector latches.

Removing/Replacing a Card in the Access Carrier

Card removal procedures differ, depending on whether you are removing the card from the front or rear of the carrier.

Removing/Replacing the NAM

1. Unscrew the captive screws from the ejector latches on front of the carrier.
2. Press open the ejector latches to disengage the card.
3. Supporting the card by its edges, pull straight out until the card clears the carrier.
4. Align the replacement card with the upper and lower tracks of the slot. Slide forward until the NAM seats. Be careful not to force or bend any pins.
5. Close both the upper and lower ejector latches on the carrier to lock in place, then tighten the captive screws.

Removing/Replacing the I/O Card

1. Remove the NAM from the carrier (see *Removing/Replacing the NAM*).
2. Remove the network, DSX-1, DTE, DBM, and COM port cables from the I/O card (if applicable).
3. Using a screwdriver, loosen the upper and lower screws fastening the card to the carrier's frame.
4. Gently pull the I/O card away from the midplane until it clears the carrier.
5. Reinstall the NAM.
6. Align the replacement I/O card with the upper and lower tracks of the slot. Push gently towards the midplane until it stops and you cannot push the card any further.
7. Alternately tighten each captive screw until the screws are all the way in.
8. Reattach the cables as appropriate.

Troubleshooting

Symptom	Possible Cause	Solutions
No power, or none of the system LEDs are lit.	The power cord is not securely plugged into the wall receptacle, or into the rear panel connector.	Check that the power cord is securely attached at both ends.
	The wall receptacle has no power.	<ol style="list-style-type: none"> 1. Check the wall receptacle power by plugging in some equipment that is known to be working. 2. Check the circuit breaker.
	LED is burned out.	Run the Lamp Test. If the LED in question does not flash with the other LEDs, then contact your service representative.
	Power supply is defective.	Contact your sales or service representative.
Power-Up Self-Test fails. Only Alarm LED is on after power-up.	The access unit has detected an internal hardware failure.	<ol style="list-style-type: none"> 1. Reset the access unit and try again. 2. Contact your service representative.

LEDs

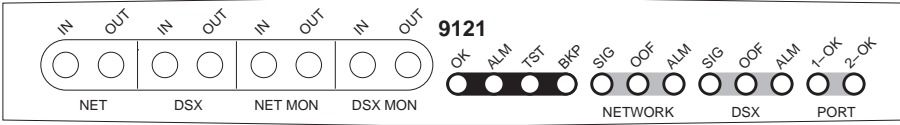

97-15315-01

Faceplate for 1-Slot Housing

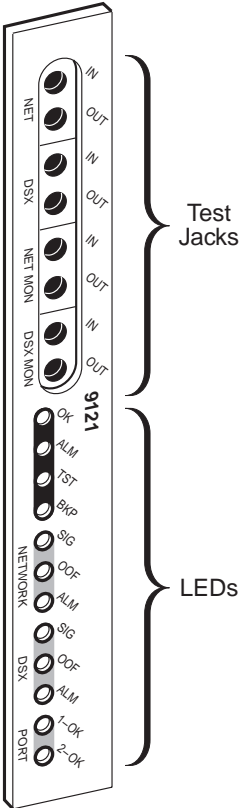

97-15051-01

The access unit's faceplate includes 12 LEDs (light-emitting diodes) that provide status on the access unit, its network and DSX interfaces, and the DTE interfaces.

Four sets of test jacks are also provided for accessing and testing toward the network and DSX. Refer to Chapter 5, *Troubleshooting and Maintenance*, of the Technical Reference for more information about the test jacks.

Faceplate for Access Carrier

FrameSaver 9120 LEDs

Label	Indication	Color	What It Means
OK	Power and Operational Status	Green	<p>ON – Access unit has power and is operational.</p> <p>OFF – Access unit is in a power-up self-test, or there is a failure.</p> <p>Blinking ON and OFF (Rate: 1 Hz) – Software is being downloaded.</p>
ALM	Operational Alarm (Fail)	Red	<p>ON – Access unit has just been reset, or an error or fault has been detected.</p> <p>OFF – No failures have been detected.</p>
TST	Test Mode	Yellow	<p>ON – Loopback or test pattern in progress, initiated locally, remotely, or from the network.</p> <p>OFF – No tests are active.</p>
BKP ¹	Backup	Yellow	<p>ON – Access unit is in Backup mode; that is, the backup link has been established, and backup is in progress through the specified Alternate Destination Link.</p> <p>OFF – Access unit is not in Backup mode.</p> <p>Blinking ON and OFF (Rate: 1 Hz) – Alternate Destination Link is being established, but no data has been passed.</p>
<p>¹ The BKP LED indicates backup for an ISDN BRI DBM or external backup device.</p>			

Network/DSX Interface LEDs

Label	Indication	Color	What It Means
SIG	Signal	Green	ON – A recoverable signal is present on the network/DSX interface. OFF – The signal cannot be recovered from the network/DSX interface. An LOS condition exists.
OOF	Out of Frame	Yellow	ON – At least one OOF was detected during the sampling period. OFF – No OOFs were detected during the sampling period.
ALM	Alarm	Yellow	ON – An alarm condition is present on the network/DSX interface. OFF – No alarm condition is present on the network/DSX interface.

DTE Port 1 or 2 LEDs

Label	Indication	Color	What It Means
1-OK 2-OK	Operational Status	Green	ON – The interchange circuits for the port are in the correct state to transmit and receive data. OFF – The port is idle. Occurs if the port is disabled, or if the port is configured to monitor DTR and/or RTS and the lead(s) is not asserted.

Technical Specifications

Specification	Criteria
Weight 1-Slot NAM Access Carrier NAM	2.59 lbs. (1.18 kg) 1.13 lbs. (0.51 kg)
1-Slot Power Power consumption and dissipation	8.7 watts, 60 Hz, 0.124 mA at 120 Vac Results: 30 Btu per hour
Access Carrier Power Power consumption	Average power 8.7 watts at 12 Vdc
Physical Environment Operating temperature Storage temperature Relative humidity Shock and vibration	35°F to 122°F (1.7°C to 50°C) -4°F to 158°F (-20°C to 70°C) 5% to 85% (nonconducting) Withstands normal shipping and handling
Approvals FCC Part 15 FCC Part 68 Industry Canada UL and CSA	Class A digital device Refer to the equipment's label for the Registration Number. Refer to the equipment's label for the Certification Number. Refer to the equipment's label.

Pin Assignments

EIA-530A DTE Ports/Interfaces

Signal	Circuit Mnemonic	ITU/ CCITT #	Direction	25-Pin Pin #
Shield	—	—	—	1
Transmitted Data (TXD)	BA	103	To DCE	2 (A) 14 (B)
Received Data (RXD)	BB	104	From DCE	3 (A) 16 (B)
Request to Send (RTS)	CA	105	To DCE	4 (A) 19 (B)
Clear to Send (CTS)	CB	106	From DCE	5 (A) 13 (B)
Data Set (or DCE) Ready (DSR)	CC	107	From DCE	6
Signal Ground/Common (SG)	AB	102A	—	7
Received Line Signal Detector (RLSD or LSD)	CF	109	From DCE	8 (A) 10 (B)
Transmit Signal Element Timing (TXC – DTE Source)	DA	113	To DCE	11 (B) 24 (A)
Transmitter Signal Element Timing (TXC – DCE Source)	DB	114	From DCE	12 (B) 15 (A)
Receiver Signal Element Timing (RXC – DCE Source)	DD	115	From DCE	17 (A) 9 (B)
Local Loopback (LL)	LL	141	To DCE	18
Data Terminal (or DTE) Ready (DTR)	CD	108/1, /2	To DCE	20
Reserved for future use	—	—	—	21
Signal Common	AC	102B	—	22, 23
Test Mode Indicator (TM)	TM	142	From DCE	25

COM Port/Interface

Signal	Direction	Pin #
DCE Transmit Clock (TXC)	From DCE (Out)	1
DCE Received Data (RXD)	From DCE (Out)	2
Signal Ground (SG)	To/From DCE	3
DCE Transmit Data (TXD)	To DCE (In)	4
DCE Data Terminal Ready (DTR)	To DCE (In)	5
DCE Carrier Detect (CD)	From DCE (Out)	6
DCE Request to Send (RTS)	To DCE (In)	7
DCE Received Clock (RXC)	From DCE (Out)	8

DSX-1 Port/Interface

Function	Circuit	Pin #
Receive tip from the DTE	T1	1
Receive ring from the DTE	R1	9
Transmit tip to the DTE	T	3
Transmit ring to the DTE	R	11
Shield	–	2, 4

NET Port/Interface

Function	Circuit	Pin #
Transmit ring to the network	R	4
Transmit tip to the network	T	5
Receive tip from the network	T1	2
Receive ring from the network	R1	1

DBM or BKP Port/Interface

Function	Circuit	Pin #
Transmit/Receive ring to/from the local loop	R	4
Transmit/Receive tip to/from the local loop	T	5

RJ48H Connector for T1 Mass Termination Cable

Function	Circuit	Line #	Pin #	Function	Circuit	Line #	Pin #
Receive ring from the network	R1	1	1	Transmit ring to the network	R	1	14
		2	2			2	15
		3	3			3	16
		4	4			4	17
		5	5			5	18
		6	6			6	19
		7	7			7	20
Receive tip from the network	T1	1	26	Transmit tip to the network	T	1	39
		2	27			2	40
		3	28			3	41
		4	29			4	42
		5	30			5	43
		6	31			6	44
		7	32			7	45

Warranty, Sales, and Service Information

Contact your local sales representative, service representative, or distributor directly for any help needed. For additional information concerning warranty, sales, service, repair, installation, documentation, training, distributor locations, or Paradyne worldwide office locations, use one of the following methods:

- **Via the Internet:** Visit the Paradyne World Wide Web site at <http://www.paradyne.com>
- **Via Telephone:** Call our automated call system to receive current information via fax or to speak with a company representative.
 - Within the U.S.A., call 1-800-870-2221
 - Outside the U.S.A., call 1-727-530-2340

Document Feedback

We welcome your comments and suggestions about this document. Please mail them to Technical Publications, Paradyne Corporation, 8545 126th Ave. N., Largo, FL 33773, or send e-mail to userdoc@eng.paradyne.com. Include the number and title of this document in your correspondence. Please include your name and phone number if you are willing to provide additional clarification.

Trademarks

All products and services mentioned herein are the trademarks, service marks, registered trademarks or registered service marks of their respective owners.